

DET	QTY	DESCRIPTION	LENGTH	TOT LG
1	1	1/2-13UNC x 5.5 ALL THD BOLT	-----	-----
2	1	CATCH	-----	-----
3	2	1/2-13UNC NUT	-----	-----
4	1	1/2 LOCK WASHER	-----	-----
5	1	1/2 LOCK NUT	-----	-----

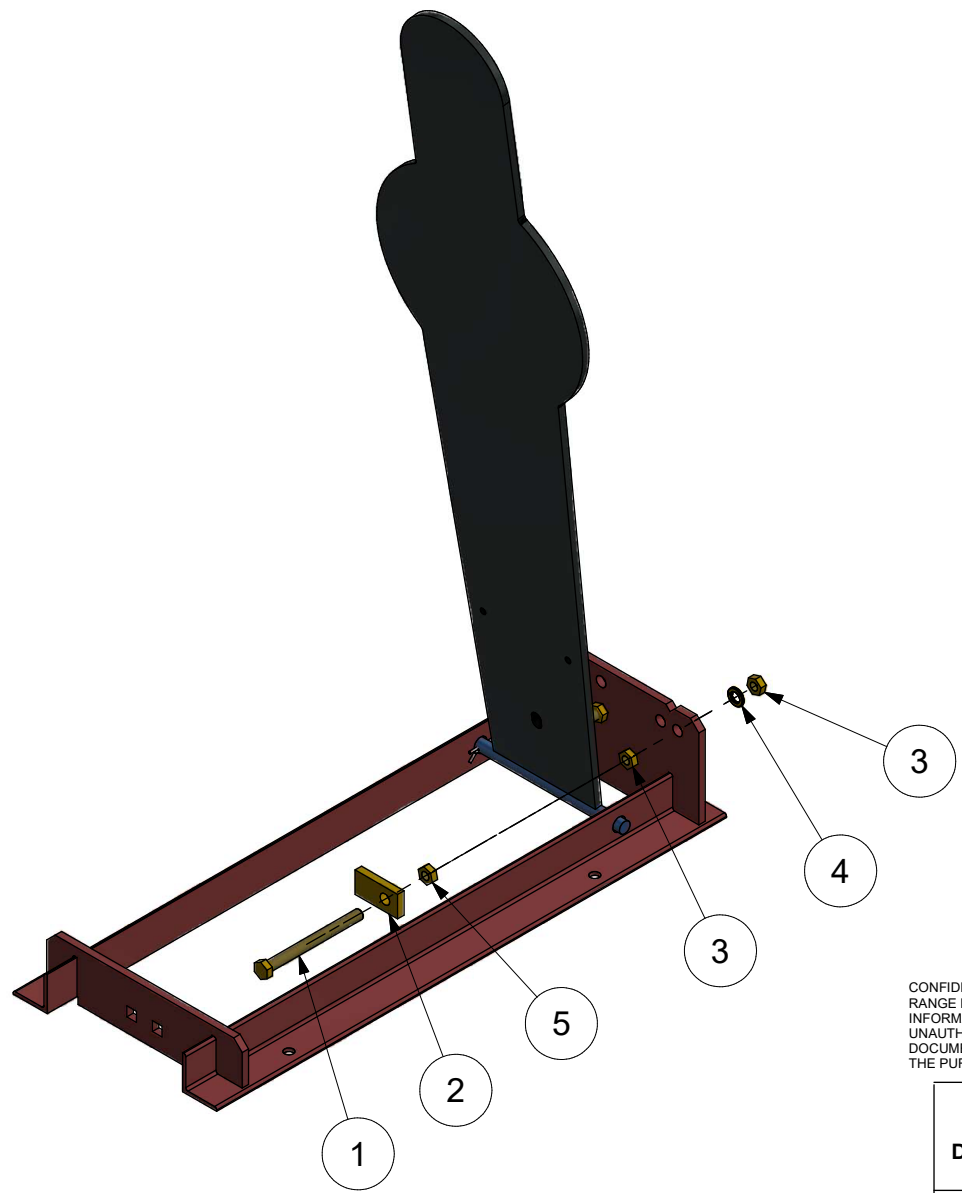

CONFIDENTIAL - THE INFORMATION CONTAINED IN THIS DOCUMENT IS THE PROPERTY OF RANGE MASTER STEEL. IT IS NOT FOR PUBLIC DISCLOSURE. POSSESSION OF THIS INFORMATION DOES NOT CONVEY THE RIGHT TO LOAN, SELL OR DISCLOSE THIS INFORMATION. UNAUTHORIZED REPRODUCTION OR USE OF THIS INFORMATION IS PROHIBITED. THIS DOCUMENT IS TO BE RETURNED TO RANGE MASTER STEEL UPON COMPLETION OF THE PURPOSE FOR WHICH IT WAS LOANED OR UPON REQUEST.

HIRST DESIGN & ENG.	HEAT TREATMENT		ENG. REF:	
	TITLE Assembly-Dwg Popper Assembly Forward Falling			
DWN BY RBH 6/24/2016	SIZE C	ENGR APPROVAL RH	DWG NO. popper-asm-forward	REV A
CK'D BY RH 6/24/2016	SCALE 1/3		SHEET 1 OF 1	